

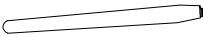





ASSEMBLY INSTRUCTIONS

CVFDR1037

PARTS

S.NO.	DESCRIPTION	QNT
A	 TOP	01
B	 LEGS	04
C	 SHELF	01

HARDWARE

S.NO.	DESCRIPTION	QNT
D	 WASHER	12
E	 SPRING WASHER	12
F	 JCBC M6 x 40	12
G	 ALLEN KEY	01

STEP - 1

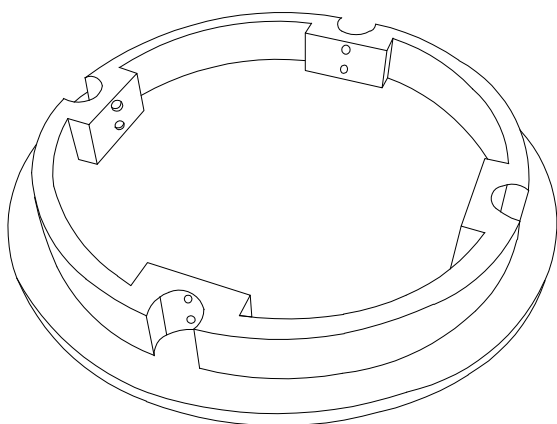

put the TOP (A) on the floor upside down

STEP - 2

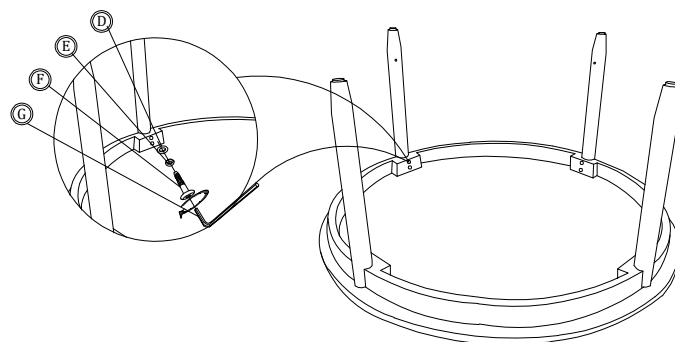

Attach to the 4 legs (B), adjust to the mount on the top(A), then attach the JCBC M6 x 40 (F) with washer (D) and spring washer (E), (tighten with allen key (G))

STEP - 3

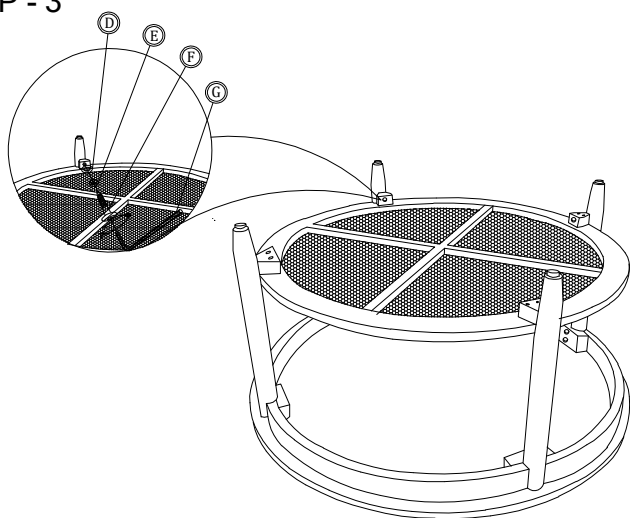

Install the shelf (C) on the legs according to the hole in the leg, Install the JCBC M6 x 40 (F) along with the washer (D) and spring washer (E), (tighten with an allen key (G))

COMPLETED

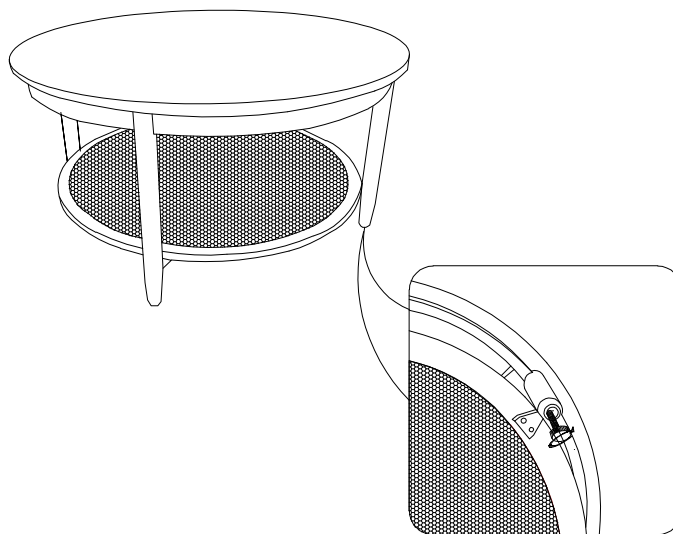

Leveller are provided at the bottom to the balance on uneven surface

MADE IN INDONESIA